



- TASTE THE DIFFERENCE -

MODEL 15RMT

This single-flavor, pressurized soft serve freezer consistently produces smooth and creamy ice cream, custard or frozen yogurt. This machine is excellent for high butterfat mixes like lowfat and premium ice cream and custard. Perfect for specialty buffets, high-volume restaurants, amusement park kiosks and additional flavors in ice cream stores

The Electro Freeze Advantage

- **Patented Mix Transfer System*** simplest and most reliable pressurized system available.
- **Flexible Mix Holding System Pumps** directly from bags or from mix containers
- **The Finest Frozen Product**, consistently the best frozen product available. Smooth, creamy and profitable.
- **Self Closing Spigots** prevents the mess and eliminates waste
- **Adjustable Dispense Rate** set to meet your specific dispensing speed and volume requirements
- **Exclusive Auger Design** Superior low temperature refrigeration system provides the best in class production and product quality.
- **Energy Conservation Mode** reduces energy cost and holds product safely during non-business hours
- **Superior Low Temperature Refrigeration System** provides the best in class production and product quality
- **Product Flexibility** serves a variety of frozen products, custard, ice cream sorbets, water ice or yogurt
- **Experience Tells** Electro Freeze has been manufacturing quality frozen treat machines since 1929. Superior engineering, product innovations, sturdy construction, quality craftsmanship and dependable performance are Electro Freeze hallmarks.
- **Superior Service Support** backed by a worldwide distributor network

*U.S. Patent #5,349,825

PRESSURIZED SOFT SERVE FREEZER

Freedom 360° Series Single Flavor



electrofreeze.com

FOR MORE INFORMATION CONTACT

800-755-4545 • sales@electrofreeze.com

15RMT Soft Serve Freezer

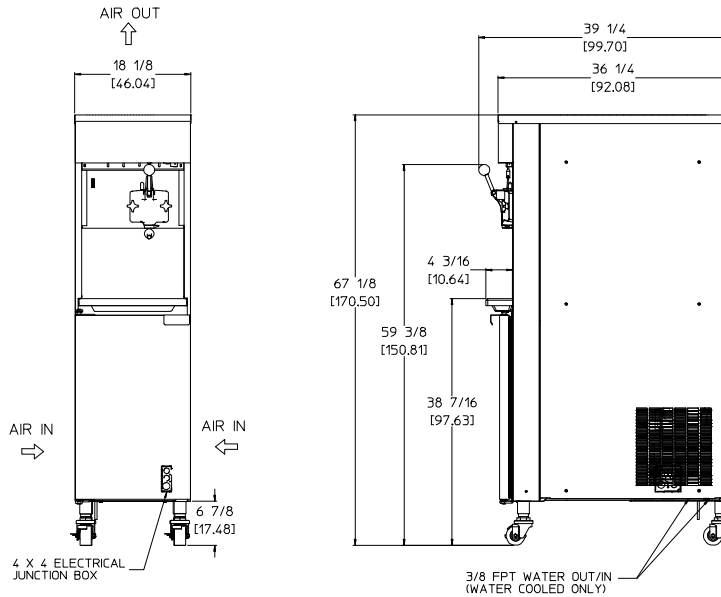

MODEL 15RMT SPECIFICATIONS

Due to continual product improvements all specifications are subject to change without notice.

Weights	lbs.	kgs.	
Net	530	240	
Crated	650	295	
	cu.ft.	cu.m.	
Volume	58.42	1.65	
Dimensions	in.	cm.	
Width	18-1/8	46.04	
Depth	36-1/4	92.08	
Height Air	67-1/8	170.50	
Height Water	67-1/8	170.50	
Electrical	Maximum Fuse Size*	Minimum Circuit Ampacity*	Poles (P) Wires (W)
208-230/60/1 Air	35	27	2P, 2W
208-230/60/1 Water	30	24.5	2P, 2W
208-230/60/3 Air	25	19	3P, 3W
208-230/60/3 Water	20	16.5	3P, 3W
	Total Amps		Poles (P) Wires (W)
380-415/3/50 Air	10.7		3P, 4W
380-415/3/50 Water	8.9		3P, 4W

Electrical characteristics other than above available on request from factory or local distributor. Check nameplate for exact electrical data.

Bidding Spec

Electrical: Volt _____ Hz _____ Ph _____
 Cooling: _____ Neutral ___ Yes ___ No
 Options: _____

Electrical

A dedicated electrical connection is required. Manufactured to be permanently connected. See electrical chart for the proper requirement. Consult your local electrical codes for cord and receptacle specifications.

Beater Motor

One, 2hp

Refrigeration Systems

One, 9500 Btuh. R404a.
 Btuh may vary depending on compressor used.

Air and Water Cooled

6" (15.2 cm) air space required at rear or both side panels for proper air circulation.

Mix Tank Capacity: 30 quarts (28.4 liters)

Freezing Cylinder Capacity: 5 quarts (4.7 liters)

Certified and/or listed by:



*UL listed and listed by Underwriters Laboratories under Canadian National Standard C22.2 No. 120-M91 (R2008)
 **Select Voltages @ 50HZ

 **Electro Freeze div. of H.C. Duke & Son, LLC**
 2116-8th Avenue, East Moline, Illinois 61244 USA
 Phone (309) 755-4553 • (800) 755-4545
 FAX (309) 755-9858
 E-mail: sales@electrofreeze.com • www.electrofreeze.com

Authorized Distributor
LOVE'S THERMAL SYSTEMS, INC.
 Wilkes-Barre / Harrisburg
 800-564-8591
 www.lovesthermal.com